

FIRECHIEF® HRE100 HOSE REEL CABINET

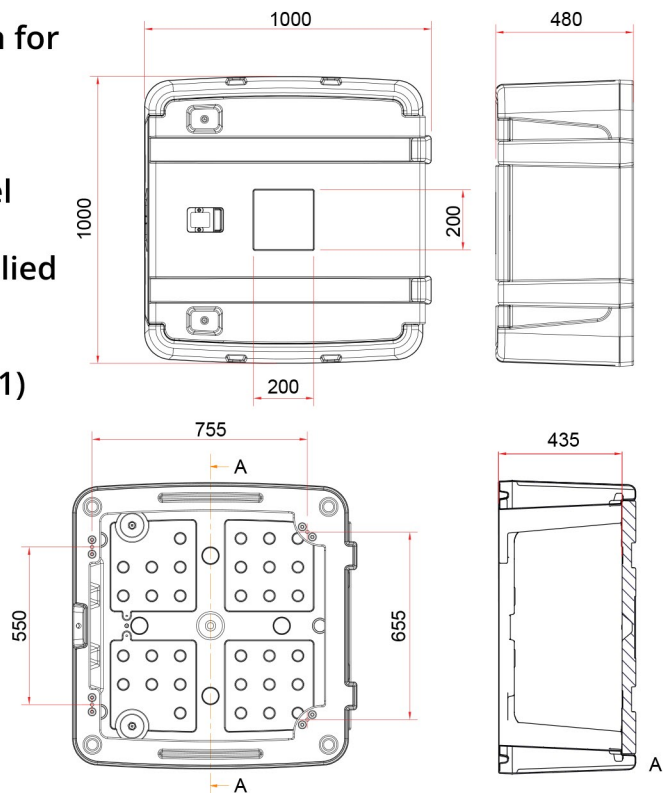

The Firechief HRE100 Hose Reel Cabinet is specifically designed to stand up to the harshest environments.

- Product Code: 106-1203
- Wall mounted, non-corroding PE cabinet for hose reels of various sizes.
- Ideal for harsh environments, e.g. abattoirs, chemical factories, marin environment etc.
- Suitable for indoor & outdoor use,
- Has 'L' shaped door to allow hose reel to pivot through 140°.
- Plastic locks & key compartment with break glass facility.
- Right or left hinger mounting
- Robust nylon hinges.
- Padlock/tamper strap facility (padlock/strap not supplied).
- Water inlet pipe aperture cut at installation for ideal fit.
- Fully recyclable, chemical resistant, UV-stabilised PE
- Lightweight - almost half the weight of steel versions, plus easier to install.
- Designated label area, Hose reel label supplied loose.
- Black body & red door as standard.
- Optional extras: Break-glass spare kit (KIT81)

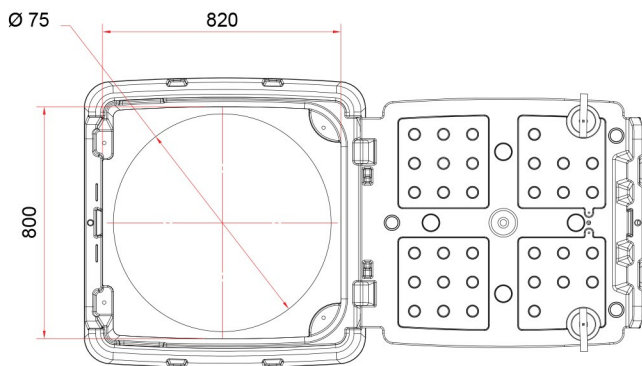

**Fire and Safety
Centre**

Available From:

Fire and Safety Centre
15 Atkinsons Way, Foxhills Industrial Estate
Scunthorpe, North Lincolnshire, DN15 8QJ
Tel: 01724 281044 **Web:** www.fireandsafetycentre.co.uk
Email: sales@fireandsafetycentre.co.uk